

Uncovering Long-Lived Doubly Charged Scalars



Nivedita Ghosh
Kavli IPMU(WPI), UTIAS, The University of Tokyo
Presented at the 16th PPP Workshop, NTHU
17.06.2026

Outline

Based on: [2602.02308](#) (Nandini Das, Dilip Kumar Ghosh, **Nivedita Ghosh**, Ritesh K. Singh)

- Introduction to Long-lived Particle (LLP)
- Model
- LLP search at the future lepton colliders
 - * International Linear Collider (ILC)
 - * International Muon Collider Collaboration (IMCC)
- Summary

Introduction to LLP

Why LLP?

- Most conventional searches at LHC assumes that the New BSM particle decays promptly.

Why LLP? 🤔

- Most conventional searches at LHC assumes that the New BSM particle decays promptly.
- But is it really necessary to assume this?

NO!!!

Why LLP? 🤔

- Most conventional searches at LHC assumes that the New BSM particle decays promptly.
- But is it really necessary to assume this?

NO!!!

- What if the NP particles have longer lifetime? → open the door to the Lifetime Frontier.

Why LLP?

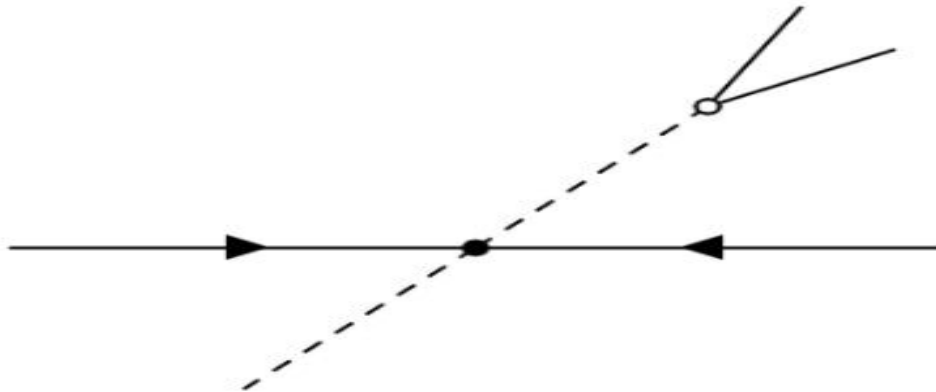

$c\tau \gtrsim 0$ (few mm)

Detection of the LLP

Production

1. Production rate
(like meson or Higgs..)
2. Boost Factor ($\beta\gamma$)

Decay

1. Proper decay length ($c\tau$)
2. Decay Products

Detection

Where does it decay?

$$d = \beta\gamma c\tau$$

Reach and coverage of LLP experiments

[1911.00481]

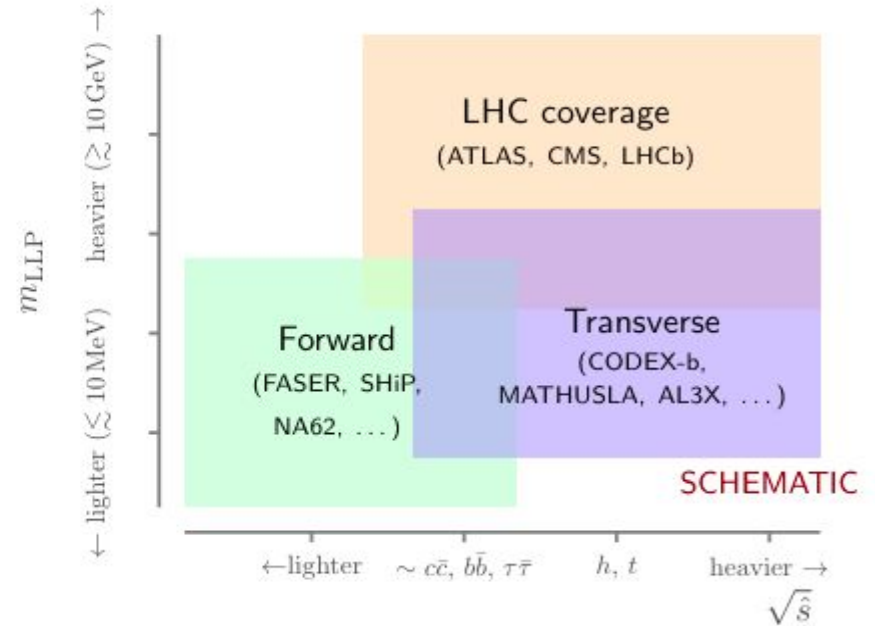
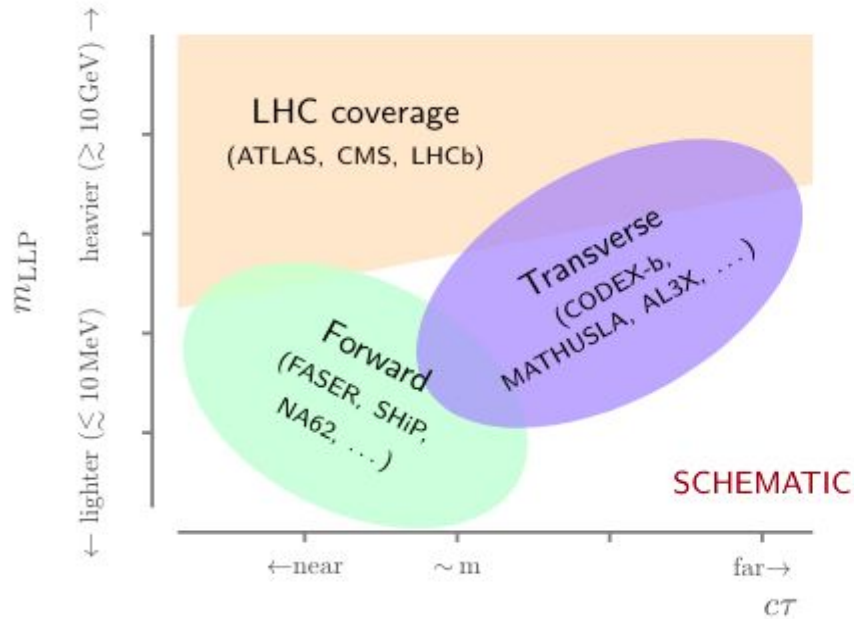

Dedicated detectors for LLPs

[Snowmass Report 2209.13128](#)

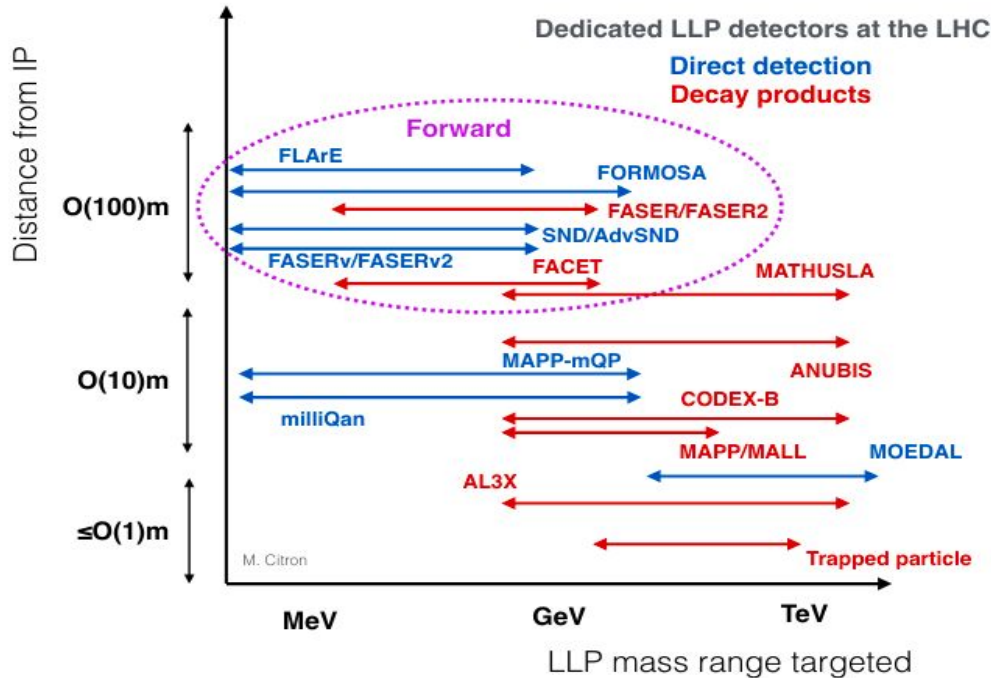

Dedicated detectors for 100 TeV

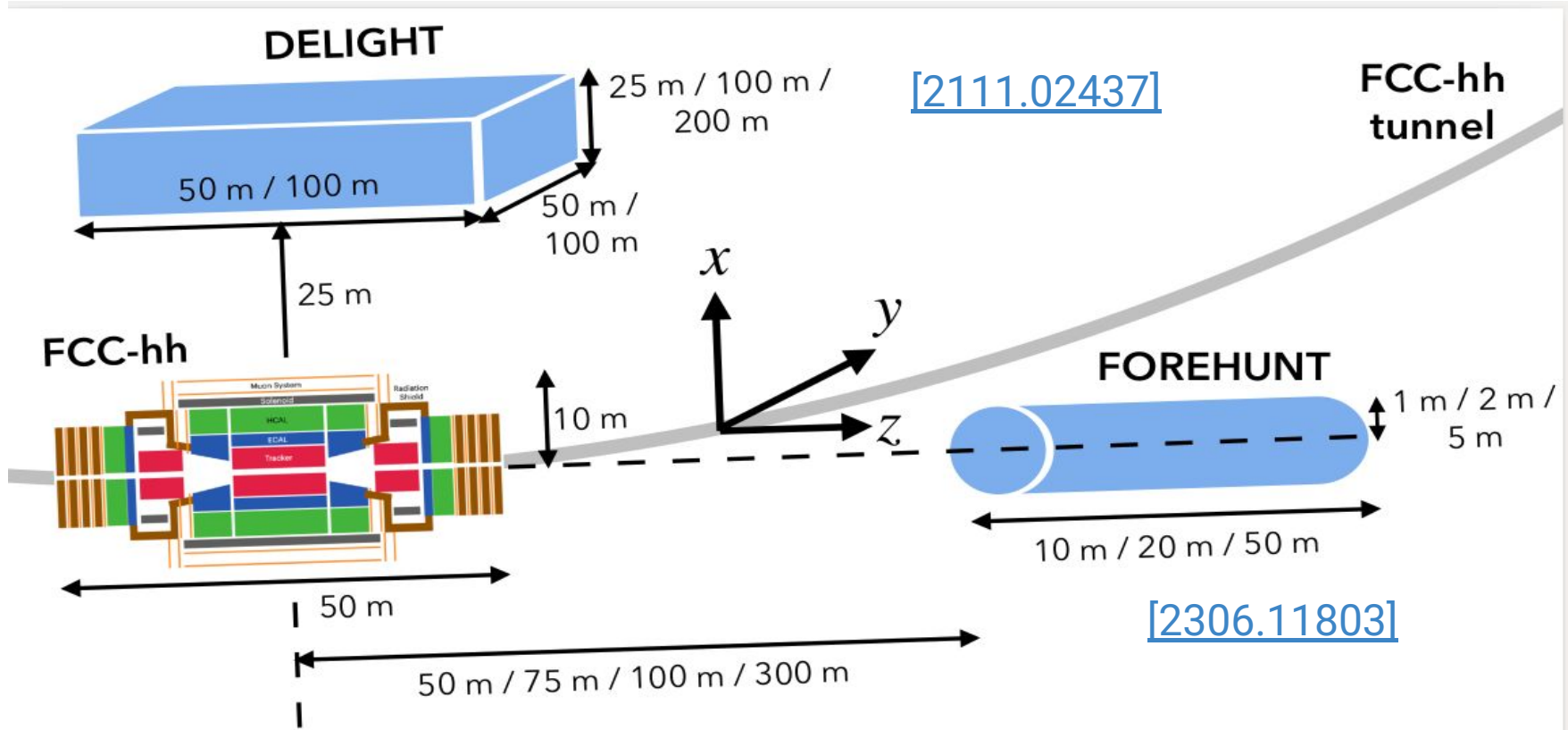

Dedicated detectors for 100 TeV

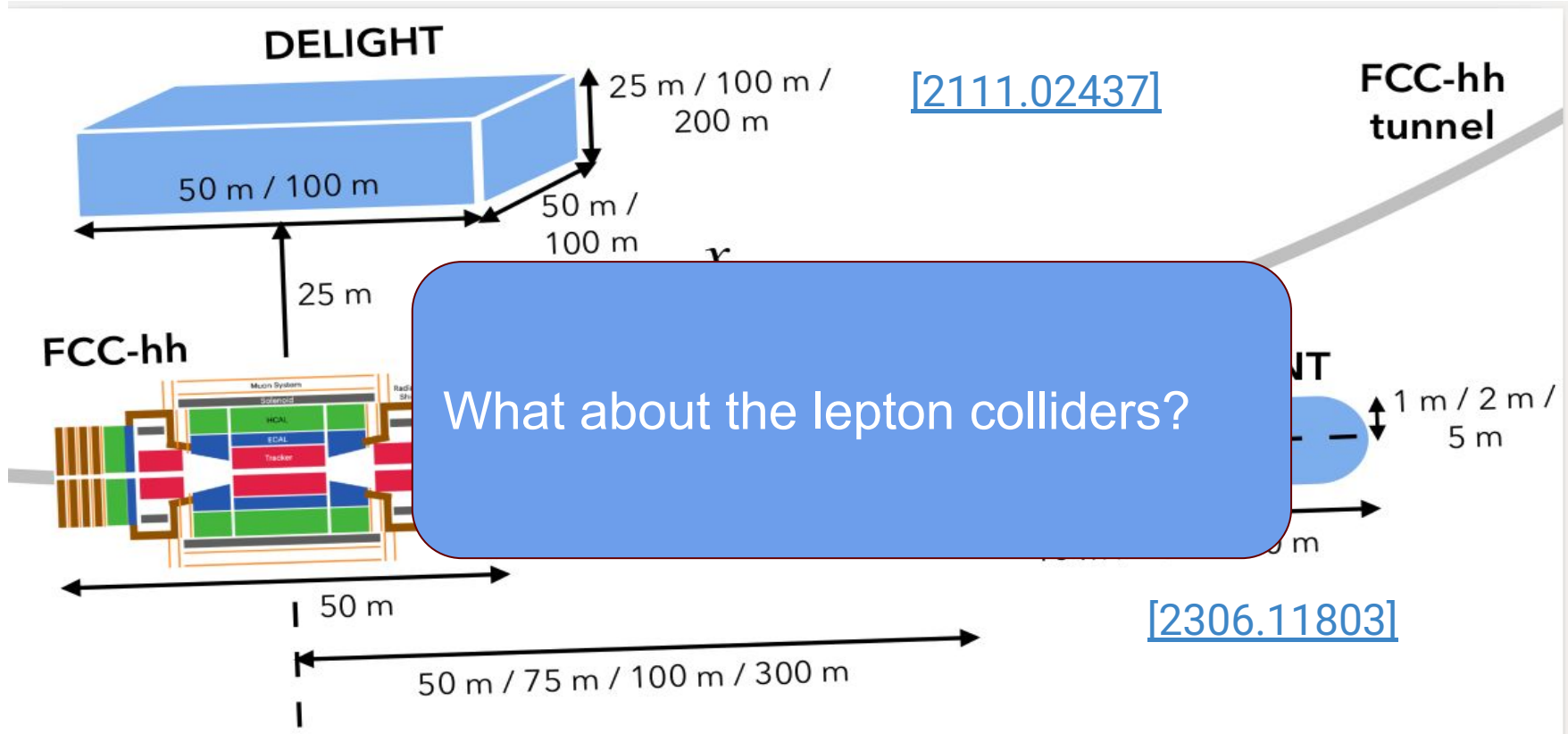

Model

$$\Delta = \frac{\sigma^i}{\sqrt{2}} \Delta_i = \begin{pmatrix} \delta^+/\sqrt{2} & \delta^{++} \\ \delta^0 & -\delta^+/\sqrt{2} \end{pmatrix}, \quad \Delta_1 = (\delta^{++} + \delta^0)/\sqrt{2}, \quad \Delta_2 = i(\delta^{++} - \delta^0)/\sqrt{2}, \quad \Delta_3 = \delta^+$$

$$\mathcal{L} = \mathcal{L}_{\text{Yukawa}} + \mathcal{L}_{\text{Kinetic}} - V(\Phi, \Delta),$$

$$\mathcal{L}_{\text{kinetic}} = (D_\mu \Phi)^\dagger (D^\mu \Phi) + \text{Tr} \left[(D_\mu \Delta)^\dagger (D^\mu \Delta) \right],$$

$$\mathcal{L}_{\text{Yukawa}} = \mathcal{L}_{\text{Yukawa}}^{\text{SM}} - (Y_\Delta)_{ij} L_i^\top C i \sigma_2 \Delta L_j + \text{h.c.} .$$

$$D_\mu \Delta = \partial_\mu \Delta + i \frac{g}{2} [\sigma^a W_\mu^a, \Delta] + i g' B_\mu \Delta \quad (a = 1, 2, 3).$$

$$V(\Phi, \Delta) = -m_{\Phi}^2(\Phi^\dagger\Phi) + \frac{\lambda}{4}(\Phi^\dagger\Phi)^2 + M_{\Delta}^2\text{Tr}(\Delta^\dagger\Delta) + \left(\mu\Phi^\text{T}i\sigma_2\Delta^\dagger\Phi + \text{h.c.}\right) + \lambda_1(\Phi^\dagger\Phi)\text{Tr}(\Delta^\dagger\Delta) + \lambda_2\left[\text{Tr}(\Delta^\dagger\Delta)\right]^2 + \lambda_3\text{Tr}(\Delta^\dagger\Delta)^2 + \lambda_4\Phi^\dagger\Delta\Delta^\dagger\Phi.$$

$$m_{\Phi}^2 = \lambda\frac{v_d^2}{4} - \sqrt{2}\mu v_t + \frac{(\lambda_1 + \lambda_4)}{2}v_t^2,$$

$$M_{\Delta}^2 = \frac{\mu v_d^2}{\sqrt{2}v_t} - \frac{\lambda_1 + \lambda_4}{2}v_d^2 - (\lambda_2 + \lambda_3)v_t^2,$$

$$v = \sqrt{v_d^2 + 2v_t^2} = 246 \text{ GeV}.$$

$$\rho = \frac{M_W^2}{M_Z^2 \cos^2 \theta_W} = \frac{1 + \frac{2v_t^2}{v_d^2}}{1 + \frac{4v_t^2}{v_d^2}}.$$

- ρ parameter close to unity \rightarrow upper bound on $v_t < 2 \text{ GeV}$ [[1811.03476](#)]

$$M_\nu = \sqrt{2}v_t Y_\Delta.$$

- For $v_t \sim \tilde{\mathcal{O}}(\text{GeV})$, the Yukawa coupling must be small, whereas an order-one neutrino Yukawa coupling ($Y_\Delta \sim \tilde{\mathcal{O}}(1)$) requires $v_t < (10^{-2} \text{ eV})$.

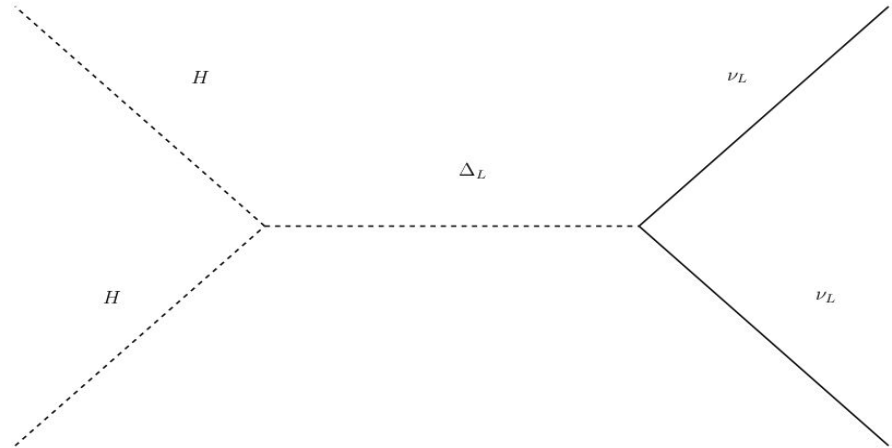

$$\Phi = \frac{1}{\sqrt{2}} \begin{pmatrix} \sqrt{2}\chi_d^+ \\ v_d + h_d + i\eta_d \end{pmatrix} \quad \Delta = \frac{1}{\sqrt{2}} \begin{pmatrix} \delta^+ & \sqrt{2}\delta^{++} \\ v_t + h_t + i\eta_t & -\delta^+ \end{pmatrix}$$

- 7 physical Higgs bosons, namely two doubly charged $H^{\pm\pm}$, two singly charged H^\pm , two CP-even neutral (h, H) and a CP-odd (A) scalar. [[1711.06062](#)]

$$\tan \beta' = \frac{\sqrt{2}v_t}{v_d}, \quad \tan \beta = \frac{2v_t}{v_d} \equiv \sqrt{2} \tan \beta'$$

$$\text{and } \tan 2\alpha = \frac{2\mathcal{B}}{\mathcal{A} - \mathcal{C}},$$

$$\text{where, } \mathcal{A} = \frac{\lambda}{2}v_d^2, \quad \mathcal{B} = v_d[-\sqrt{2}\mu + (\lambda_1 + \lambda_4)v_t], \quad \mathcal{C} = \frac{\sqrt{2}\mu v_d^2 + 4(\lambda_2 + \lambda_3)v_t^3}{2v_t}.$$

$$\begin{aligned}
\lambda &= \frac{2}{v_d^2} (c_\alpha^2 m_h^2 + s_\alpha^2 m_H^2), \\
\lambda_1 &= \frac{4m_{H^\pm}^2}{v_d^2 + 2v_t^2} - \frac{2m_A^2}{v_d^2 + 4v_t^2} + \frac{\sin 2\alpha}{2v_d v_t} (m_h^2 - m_H^2), \\
\lambda_2 &= \frac{1}{v_t^2} \left[\frac{1}{2} (s_\alpha^2 m_h^2 + c_\alpha^2 m_H^2) + \frac{1}{2} \frac{v_d^2 m_A^2}{v_d^2 + 4v_t^2} - \frac{2v_d^2 m_{H^\pm}^2}{v_d^2 + 2v_t^2} + m_{H^{\pm\pm}}^2 \right], \\
\lambda_3 &= \frac{1}{v_t^2} \left[\frac{2v_d^2 m_{H^\pm}^2}{v_d^2 + 2v_t^2} - m_{H^{\pm\pm}}^2 - \frac{v_d^2 m_A^2}{v_d^2 + 4v_t^2} \right], \\
\lambda_4 &= \frac{4m_A^2}{v_d^2 + 4v_t^2} - \frac{4m_{H^\pm}^2}{v_d^2 + 2v_t^2}, \\
\mu &= \frac{\sqrt{2}v_t m_A^2}{v_d^2 + 4v_t^2},
\end{aligned}$$

Theoretical and Experimental Constraints

- Vacuum Stability: The scalar potential has to be bounded from below [[1105.1925](#)]

$$\begin{aligned}\lambda &\geq 0, \\ \lambda_2 + \lambda_3 &\geq 0, \\ \lambda_2 + \frac{\lambda_3}{2} &\geq 0, \\ \lambda_1 + \sqrt{\lambda(\lambda_2 + \lambda_3)} &\geq 0, \\ \lambda_1 + \sqrt{\lambda\left(\lambda_2 + \frac{\lambda_3}{2}\right)} &\geq 0, \\ \lambda_1 + \lambda_4 + \sqrt{\lambda(\lambda_2 + \lambda_3)} &\geq 0, \\ \lambda_1 + \lambda_4 + \sqrt{\lambda\left(\lambda_2 + \frac{\lambda_3}{2}\right)} &\geq 0.\end{aligned}$$

- Perturbative Unitarity : The tree-level unitarity demands the eigenvalues to be bounded from above [[1105.1925](#)]

$$|\lambda_1 + \lambda_4| \leq 16\pi,$$

$$|\lambda_1| \leq 16\pi,$$

$$|2\lambda_1 + 3\lambda_4| \leq 32\pi,$$

$$|\lambda| \leq 32\pi,$$

$$|\lambda_2| \leq 8\pi,$$

$$|\lambda_2 + \lambda_3| \leq 8\pi,$$

$$|\lambda + 4\lambda_2 + 8\lambda_3 \pm \sqrt{(\lambda - 4\lambda_2 - 8\lambda_3)^2 + 16\lambda_4^2}| \leq 64\pi,$$

$$|3\lambda + 16\lambda_2 + 12\lambda_3 \pm \sqrt{(3\lambda - 16\lambda_2 - 12\lambda_3)^2 + 24(2\lambda_1 + \lambda_4)^2}| \leq 64\pi,$$

$$|2\lambda_1 - \lambda_4| \leq 16\pi,$$

$$|2\lambda_2 - \lambda_3| \leq 16\pi.$$

- Electroweak Precision Test: The strongest bound comes from the T-parameter, which imposes a strict limit on the mass splitting between the doubly and singly charged scalars, $\Delta M \equiv | m_{H^{\pm\pm}} - m_{H^\pm} | \equiv | m_{H^\pm} - m_H / m_A |$ which should be $\lesssim 40$ GeV [[1209.1303](#)]
- Higgs Signal Strength: Higgs to di-photon signal strength is within 2σ limit of the current experimental bound 1.13 ± 0.09 [[2207.00043](#)].

- Experimental bound on scalar masses: The direct search on the singly charged scalar in LEP II places a limit on $m_{H^\pm} \geq 80$ GeV [[1301.6065](#)]

LHC has also searched for the decay of $t \rightarrow H^+ b$ [[2412.17584](#)], $H^+ \rightarrow tb$ [[ATLAS-CONF-2016-089](#)], $H^+ \rightarrow W^+ h$ [[2411.03969](#)].

Non-standard neutral Higgs searches have also been done in detail at the LHC [[1710.01123](#), [2009.14791](#)].

The search for doubly charged Higgs in the multi-lepton final state is done in ATLAS [[2211.07505](#)] assuming that the doubly charged Higgs decays promptly and masses $\in [300 : 1080]$ GeV have been excluded. There is also a bound on doubly-charged Higgs from the production of same-sign W-boson pairs $\in [200 : 220]$ GeV [[1808.01899](#)]. CMS has also searched for the doubly-charged scalar at 13 TeV [[1709.05822](#), [2104.04762](#)].

However, all searches assume that the scalar decays promptly.

Long-lived Doubly Charged Scalar

If $v_t < 10^{-4}$ GeV , pair of di-leptons , else it goes to pair of di-bosons

In the crossover region, $H^{\pm\pm} \rightarrow W^\pm (W^\pm)^* \rightarrow W^\pm f f'$

By appropriately tuning v_t and $m_{H^{\pm\pm}}$, the total decay width $\Gamma \lesssim 10^{-14}$ GeV $^{-1}$ $\rightarrow c\tau \gtrsim O(\text{mm})$.

For $m_{H^{\pm\pm}} \in [89, 200]$ GeV and $v_t \in [10^{-4}, 10^{-3}]$ GeV, a region of parameter space remains unconstrained.

[1811.03476]

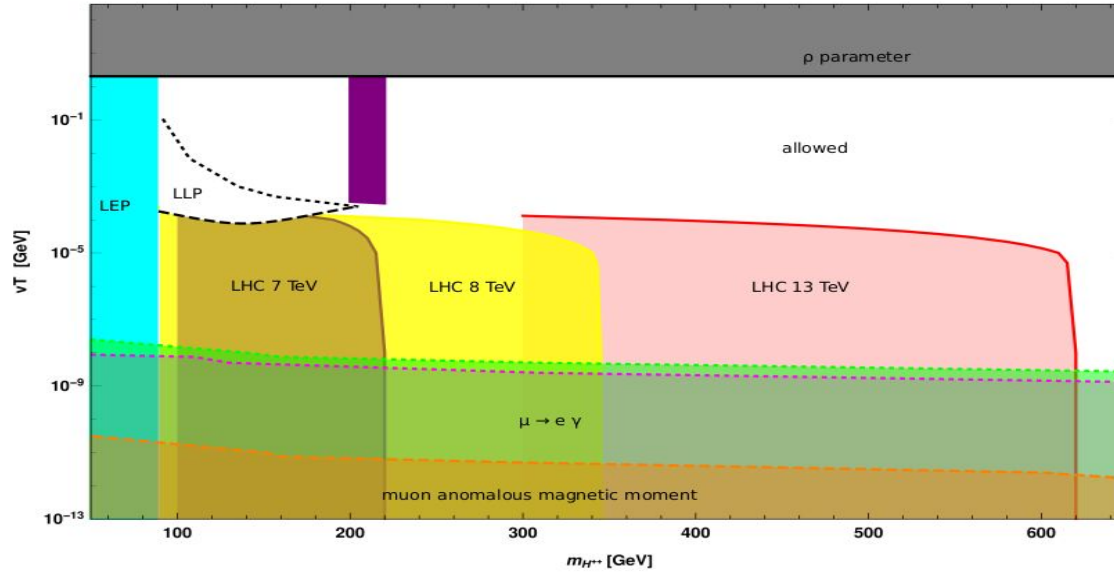

	$H^{\pm\pm}$ (GeV)	v_t (GeV)	$c\tau$ (mm)
BP1	100	9.0×10^{-4}	26.2
BP2	120	5.0×10^{-4}	8.6
BP3	180	1.6×10^{-4}	0.14

Pair Production of the doubly-charged @ILC ($\sqrt{s} = 500\text{GeV}$)

$$e^+e^- \rightarrow H^{++}H^{--}, H^{\pm\pm} \rightarrow \mu^\pm\mu^\pm$$

The SM background comes from the di-boson final state.

$$|\eta(\ell)| < 2.5; \quad p_T(\ell) > 10 \text{ GeV}; \quad \Delta R_{\ell\ell} \geq 0.4$$

σ_{ILC}	BP1	BP2	BP3	SM Bkgd
(fb)	12.18	7.18	0.62	0.64

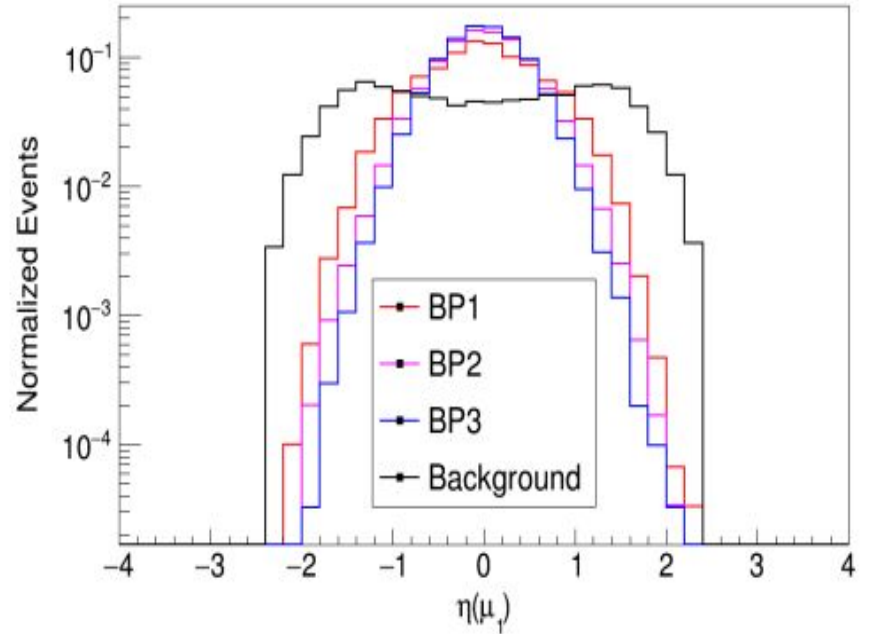
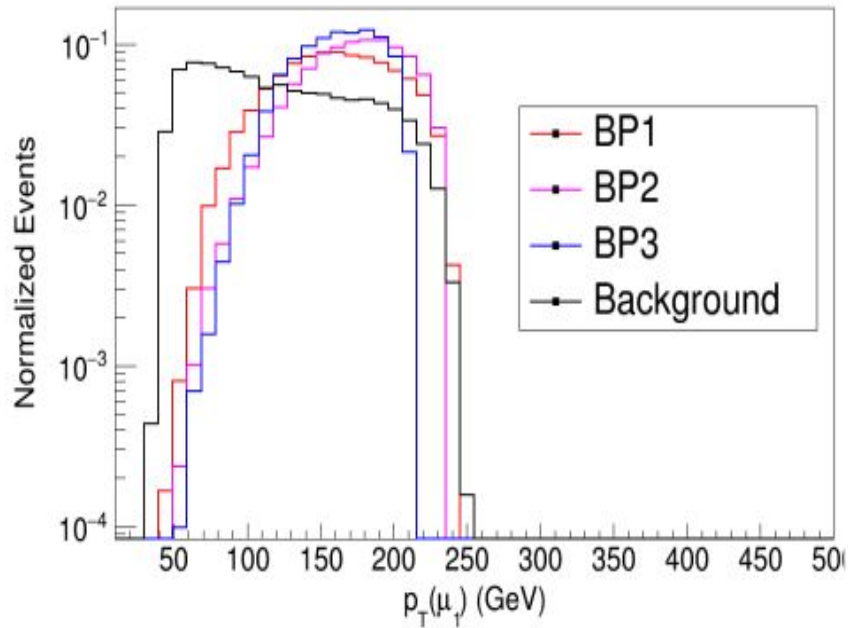

- $p_T(l) > 30$ GeV
- $|\eta_l| < 2.0$

[\[hep-ph/0508097\]](https://arxiv.org/abs/hep-ph/0508097)

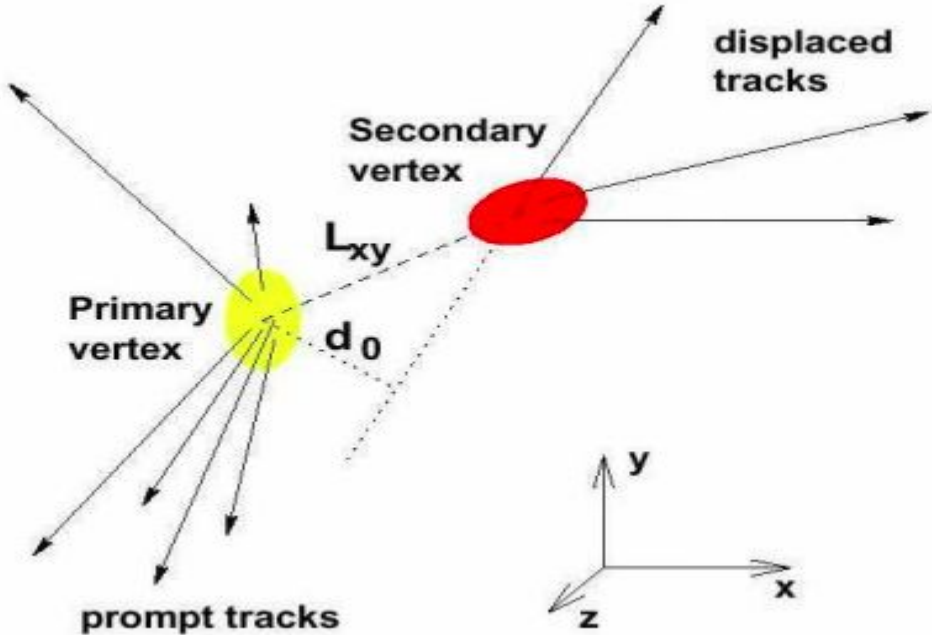

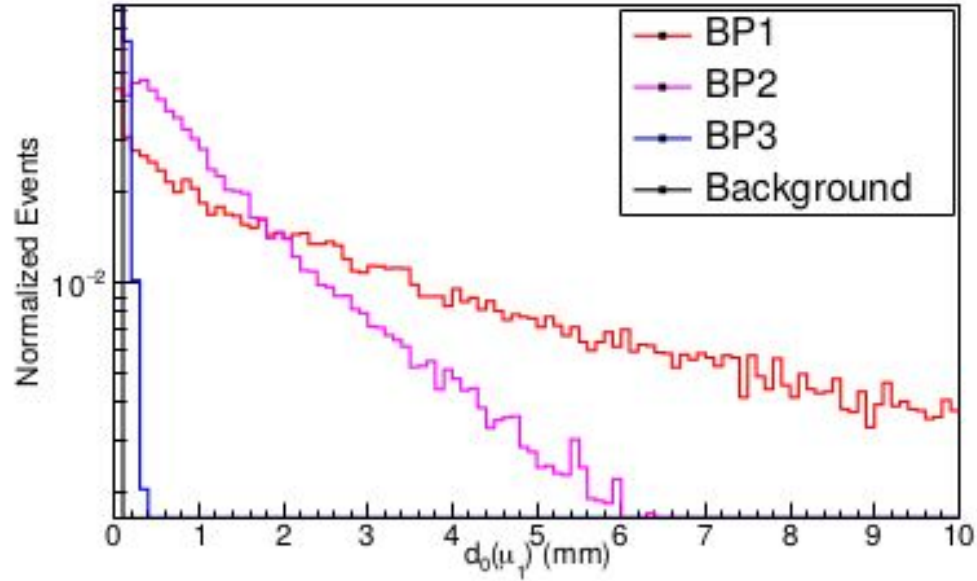

- Demanding 4 muons with $|d_0| > 0.1$ mm, we can see 16984, 7014 and 18 events for BP1, BP2 and BP3 respectively at 4 ab^{-1} luminosity.

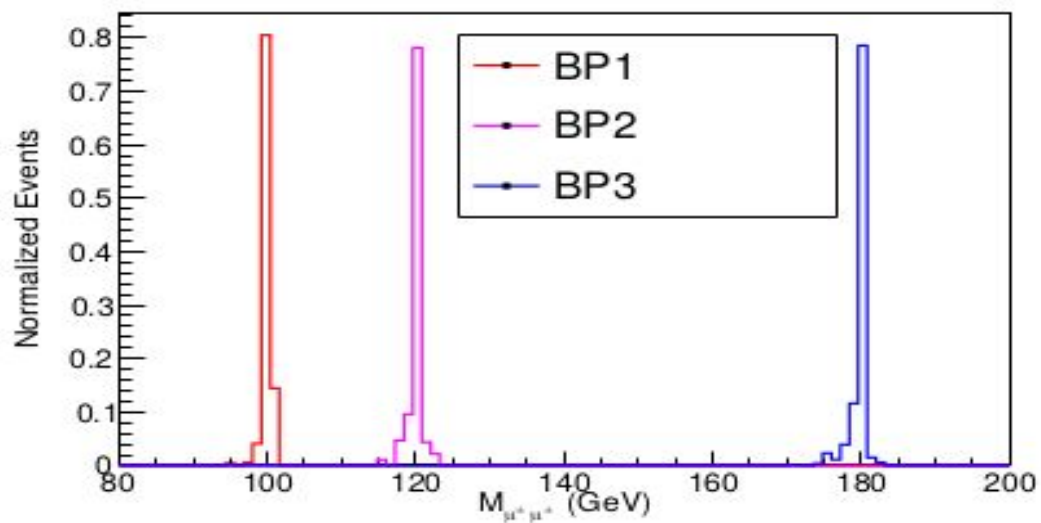

Benchmark Points	Luminosity required for 5 events after $ d_0 > 0.1\text{mm}$ cut (\mathcal{L}_5) (fb^{-1})
BP1	1.1
BP2	2.9
BP3	1111.1

Pair Production of the Doubly Charged Higgs at the Muon Collider with $\sqrt{s} = 10 \text{ TeV}$

$$\mu^+ \mu^- \rightarrow H^{++} H^{--} x y, H^{\pm\pm} \rightarrow \mu^\pm \mu^\pm$$

where $\{x, y = \mu^\pm, \nu_\ell\}$.

$$|\eta(\ell)| < 3.0; \quad p_T(\ell) > 10 \text{ GeV}; \quad \Delta R_{\ell\ell} \geq 0.2.$$

σ_{IMCC}	BP1	BP2	BP3
(fb)	0.09	0.06	0.006

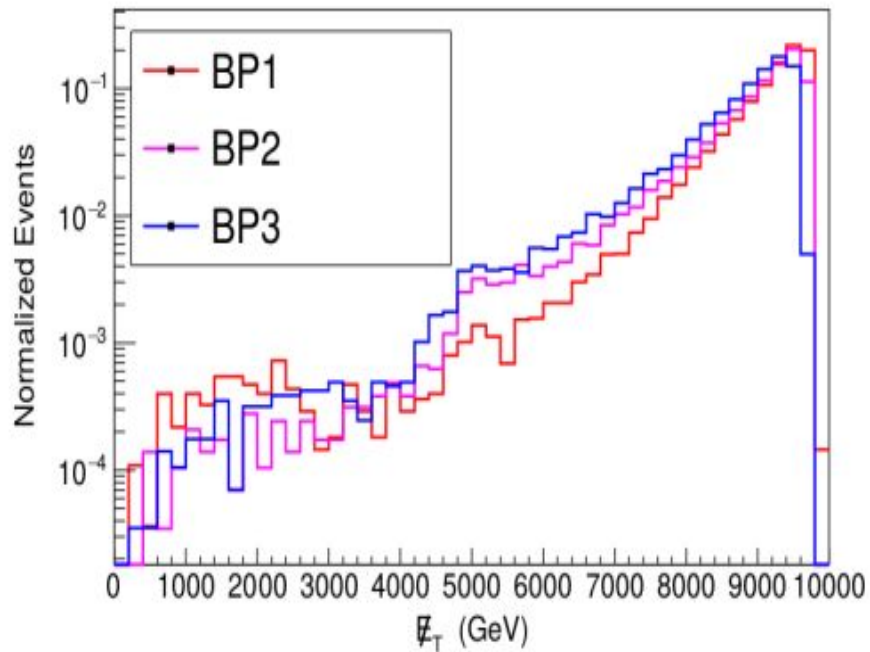
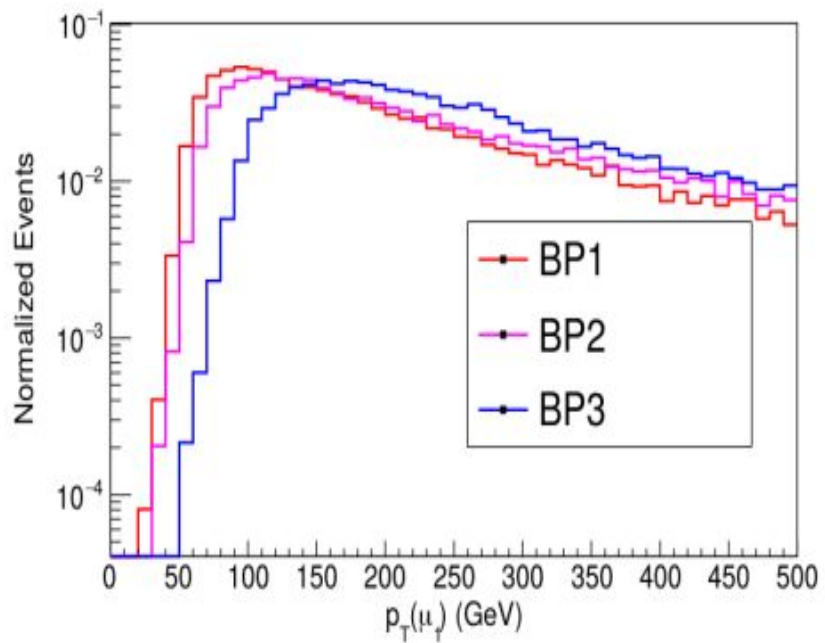

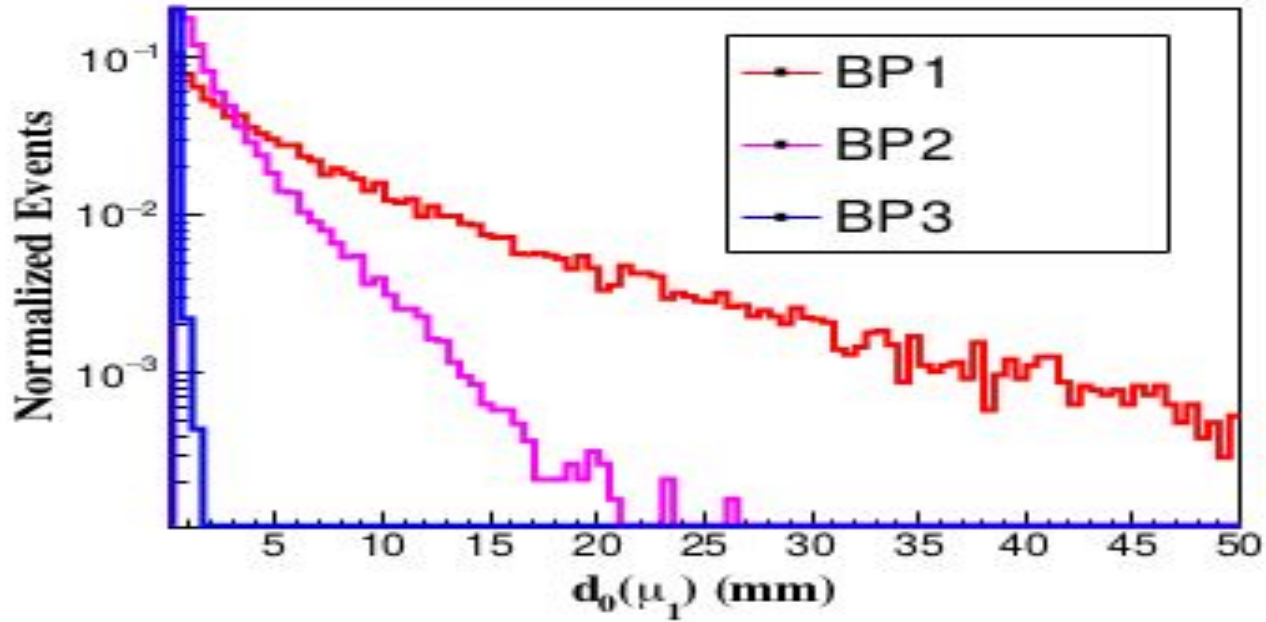

- Demanding 4 muons with $|d_0| > 0.1$ mm, we can see 323 and 195 events for BP1 and BP2 respectively at 10 ab^{-1} luminosity.

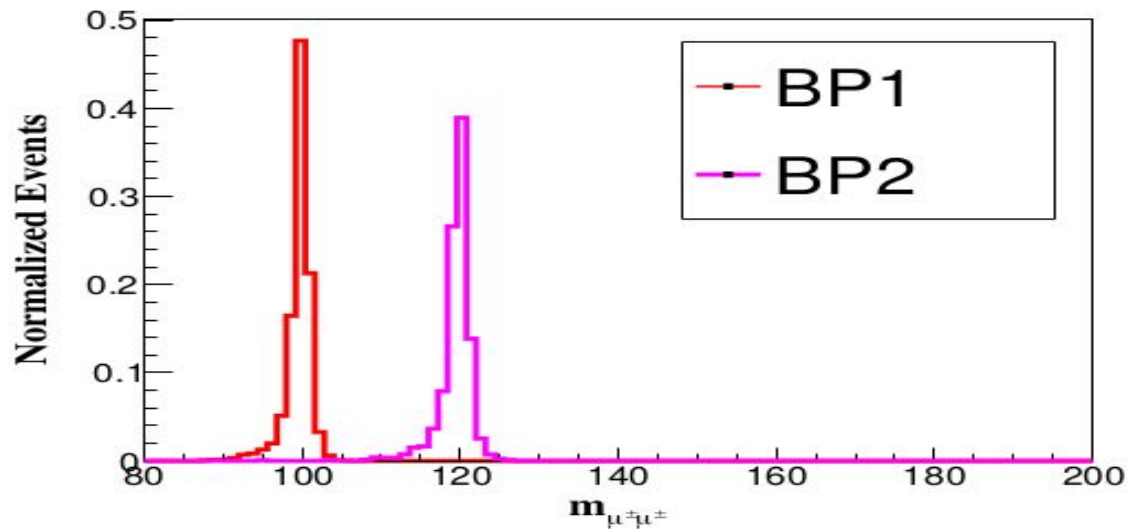

Benchmark Points	\mathcal{L}_{int} required to see 5 events after $ d_0 > 0.1\text{mm}$ cut (fb^{-1})
BP1	155
BP2	256

Summary

- We investigate the discovery prospects of long-lived doubly charged scalars at future lepton colliders within the framework of the Type-II seesaw model.
- We focus on a parameter region where the doubly charged scalar behaves as a long-lived particle, satisfy all current theoretical and experimental constraints and is accessible at the ILC and a high-energy muon collider.
- Standard Model backgrounds can be effectively suppressed by exploiting displaced vertex information through a cut on the impact parameter d_0 .

Summary

- The clean experimental environment of lepton colliders enables mass reconstruction from same-sign di-muon pairs, significantly enhancing the discovery potential.
- The unique capability of future lepton colliders to explore long-lived particle signatures provides a compelling physics case for their role in probing extended scalar sectors beyond the SM.

